

REV.	DESCRIPTION	DATE
B/0	升 B 版	2016.12.26

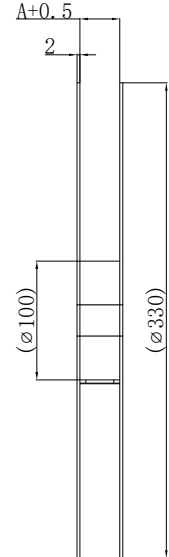

Note:

- Sprocket holes pitch cumulative tolerance ± 0.1 . (Accumulative Pitch ± 0.2)
- Carrier camber is within 1mm in 100mm.
- Number of connectors: 5000Pcs/REEL
- All dimensions meet EIA-481-D requirements.
- Thick ness: 0.4 ± 0.1 mm.
- Material of top fape: PET, PE, PEF
- Material of carrier fape: Poystyrene
- For tape width (dimension A) 16mm and 24mm a pilot hole is provided on one side. For tape width (dimension A) 32mm and 44mm pilot holes are provided on both sides.

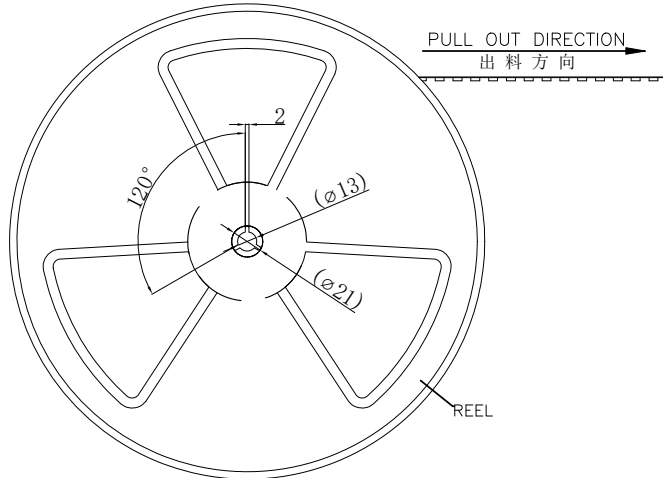
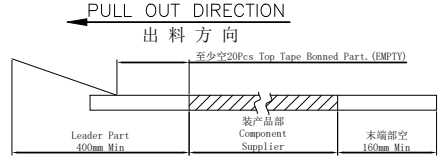

载带带头及带尾尺寸
Lead tape length

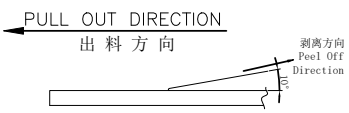

载带上下带剥离强度:
0.1N--1.3N(10g-130g)
Peeling off force of top tape:
0.1N--1.3N(10g-130g)

ROHS管理规定:
1、禁止使用含有ROHS指令所限制的物质。
2、对应的SGS或ITS出具的ICP-AES数据、不可测定物质的成分表, 有效期一年。

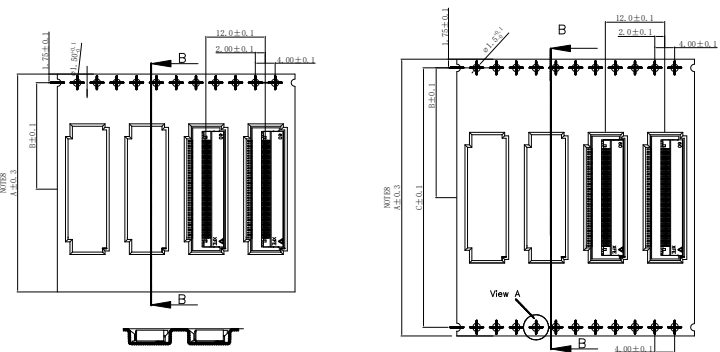
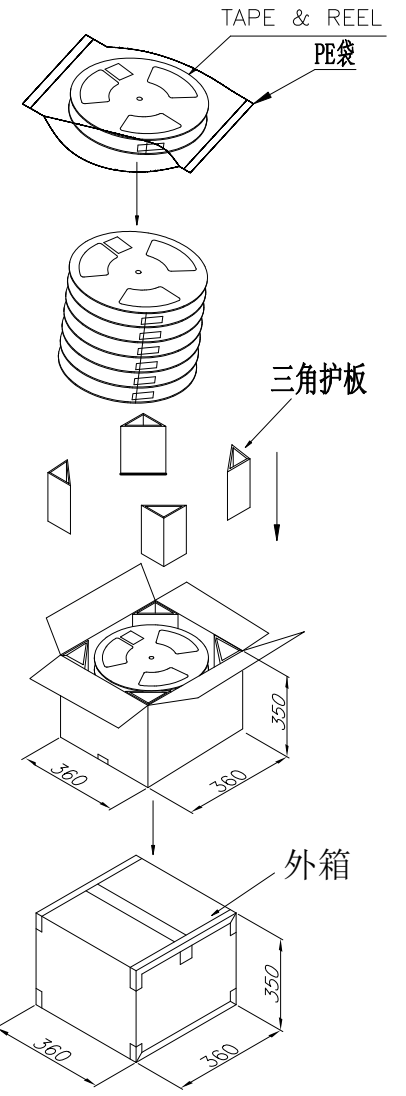

PULL OUT DIRECTION
出料方向
宽度:16mm/24mm 载带

PULL OUT DIRECTION
出料方向
宽度:32mm及以上 载带

借用登记
旧底图总号
底图总号

PART No.	60082-**0*-50**			
REEL WIDTH	24	32	44	56
PCS/REEL	2000			
REEL/BOX	12	9	7	5
BOX/PCS	24K	18K	14K	10K
CTN. SIZE	360*360*350			

GENERAL TOLERANCES		
0.X	± 0.25	X. $^{\circ}$ $\pm 3^{\circ}$
0.XX	± 0.12	
0.XXX	± 0.05	X.X. $^{\circ}$ $\pm 0.5^{\circ}$
UNIT	SIZE	SCALE
MM	A4	1:1

DRAWN BY	赵博博/2016.12.26
CHK. BY	崔华文/2016.12.26
APRV. BY	洪新江/2016.12.26
DRAWING NO.	004-0082-001

ZXF E 新富尔电子有限公司
XINFUER ELECTORN CO.,LTD

SHEET 1 OF 1
PROD. NAME 0.5-09-nPBX
PART NO. 60082-**07-50**

TITLE
0.5 FPC CONN. ZIF SMT FRONTFLIP H=1.2 BLACKLIP LOWER CONTACT

芯数 Pin (n)	PART NO.	尺寸 Size		
		A	B	C
9-20	60082-0907-50**---60082-2007-50**	24.0	11.5	---
24-30	60082-2407-50**---60082-3007-50**	32.0	14.2	28.4
40-51	60082-4007-50**---60082-5107-50**	44.0	20.2	40.4
60	60082-6007-50**	56.0	26.2	52.4