

REV.	DESCRIPTION	DATE
B/0	升版	2017.05.04

- Note:
- 1.Sprocket holes pitch cumulative tolerance  $\pm 0.1$ . (Accumulative Pitch  $\pm 0.2$ )
  - 2.Carrier camber is within 1mm in 100mm.
  - 3.Number of connectors: 800Pcs/REEL
  - 4.All dimensions meet EIA-481-D requirements.
  - 5.Thick ness:  $0.4 \pm 0.1$ mm.
  - 6.Material of top fape: PET, PE, PEF
  - 7.Material of carrier fape: Poystyrene
  - 8.For tape width (dimension A) 16mm and 24mm a pilot hole is provided on one side. For tape width (dimension A) 32mm and 44mm pilot holes are provided on both sides.

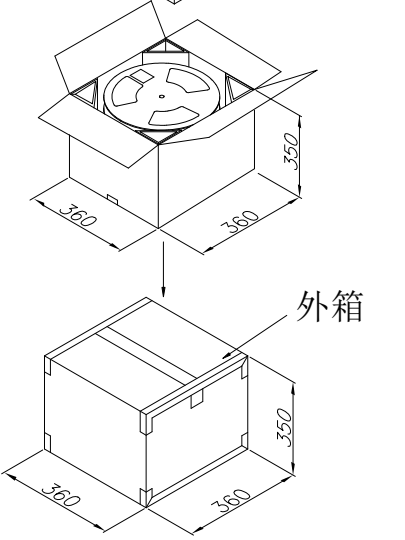
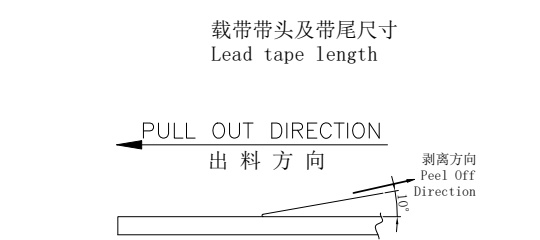
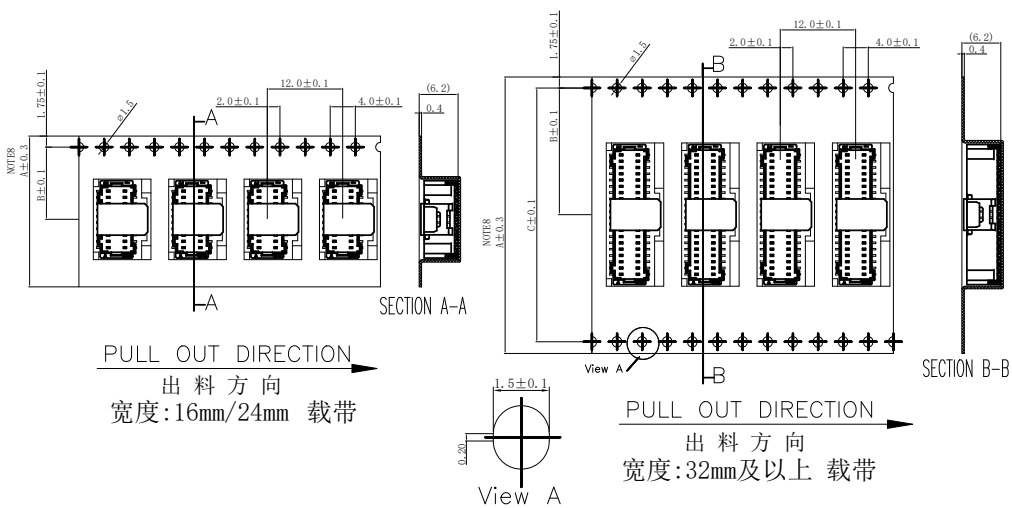
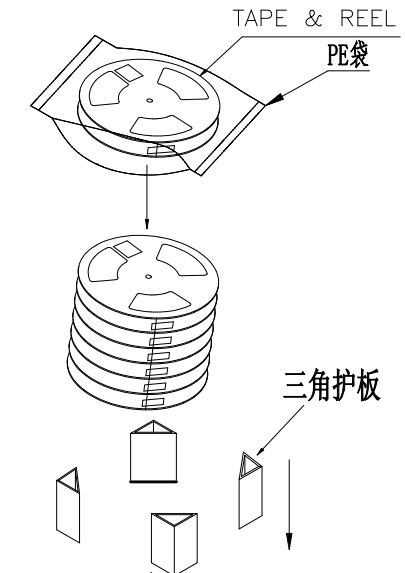
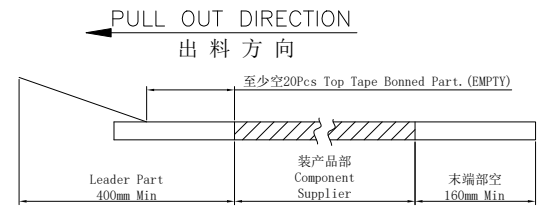
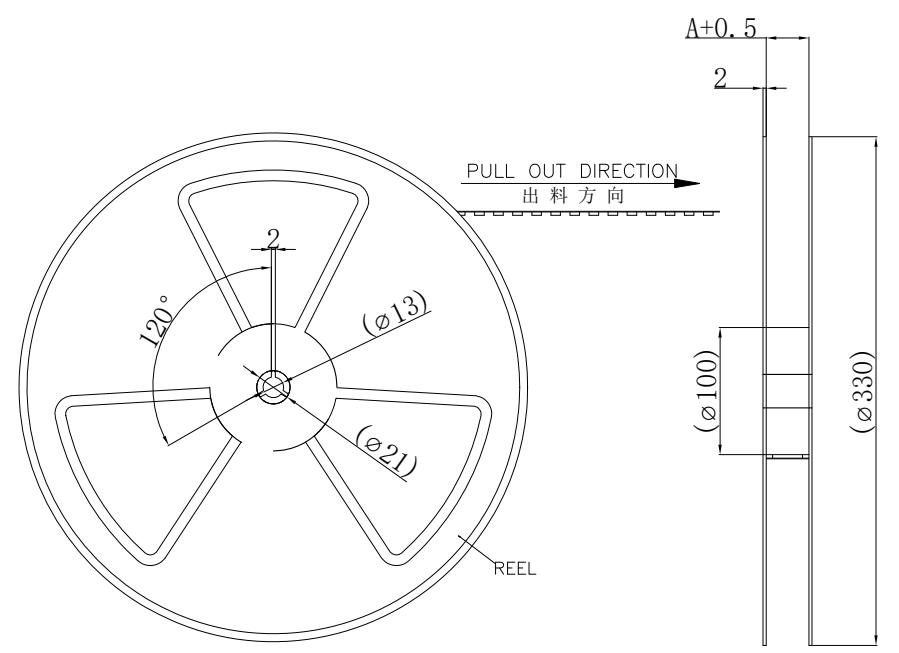

载带上下带剥离强度: 0.1N--1.3N (10g-130g)  
Peeling off force of top tape: 0.1N--1.3N (10g-130g)

- ROHS管理规定:
- 1、禁止使用含有ROHS指令所限制的物质。
  - 2、对应的SGS或ITS出具的ICP-AES数据、不可测定物质的成分表，有效期一年。

借用登记  
旧底图总号  
底图总号  
签字  
日期

芯数 Pin (n)	PART NO.	尺寸 Size		
		A	B	C
10-20	61060-100*-1001---61060-200*-1001	24.0	11.5	---
30	61060-300*-1001	32.0	14.2	28.4
40-50	61060-400*-1001---61060-500*-1001	44.0	20.2	40.4

PART No.	61060-**-1001			
REEL WIDTH	24	32	44	
PCS/REEL	800			
REEL/BOX	12	9	7	
BOX/PCS	9.6K	7.2K	5.6K	
CTN. SIZE	360*360*350			

GENERAL TOLERANCES			DRAWN BY	赵博博/2017.05.04
0.X	$\pm 0.25$	X.* $\pm 3^{\circ}$	CHK. BY	崔华文/2017.05.04
0.XX	$\pm 0.12$		APRV. BY	洪新江/2017.05.04
0.XXX	$\pm 0.05$	X.X.* $\pm 0.5^{\circ}$	DRAWING NO.	004-1060-001
UNIT	SIZE	SCALE		
MM	A4	1:1		

SHEET		PROD. NAME		SHD-nAB-DK	
1 OF 1		PART NO.		61060-**-1001	
TITLE		1.0 WTB CONN. SMT DUAL ROW VERTICAL			



新富尔电子有限公司  
XINFUER ELECTORN CO.,LTD