

REV.	DESCRIPTION	DATE
B/0	升B版	2017.05.02

- Note:
- 1.Sprocket holes pitch cumulative tolerance ± 0.1 . (Accumulative Pitch ± 0.2)
 - 2.Carrier camber is within 1mm in 100mm.
 - 3.All dimensions meet EIA-481-D requirements.
 - 4.Thick ness: 0.4 ± 0.1 mm.
 - 5.Material of top fape: PET, PE, PEF
 - 6.Material of carrier fape: Poystyrene
 - 7.For tape width (dimension A) 16mm and 24mm a pilot hole is provided on one side. For tape width (dimension A) 32mm and 44mm pilot holes are provided on both sides.

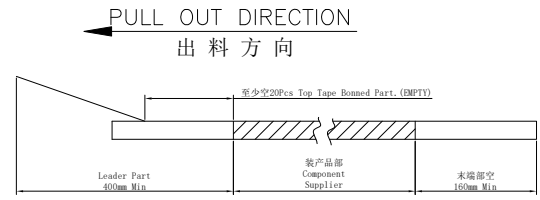

载带带头及带尾尺寸
Lead tape length

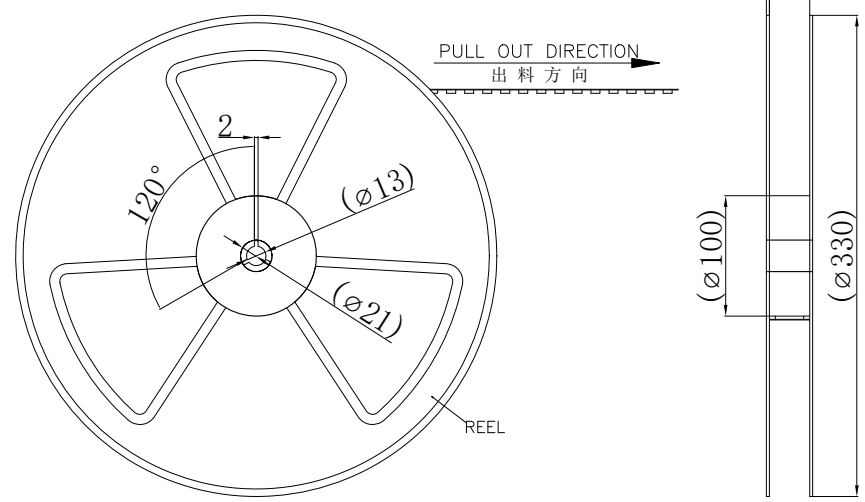
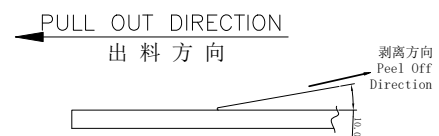

载带上下带剥离强度: 0.1N--1.3N(10g-130g)
Peeling off force of top tape:
0.1N--1.3N(10g-130g)

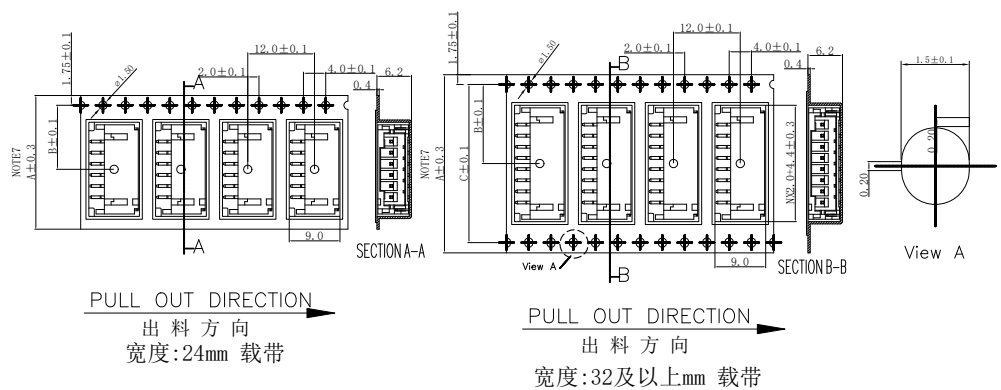
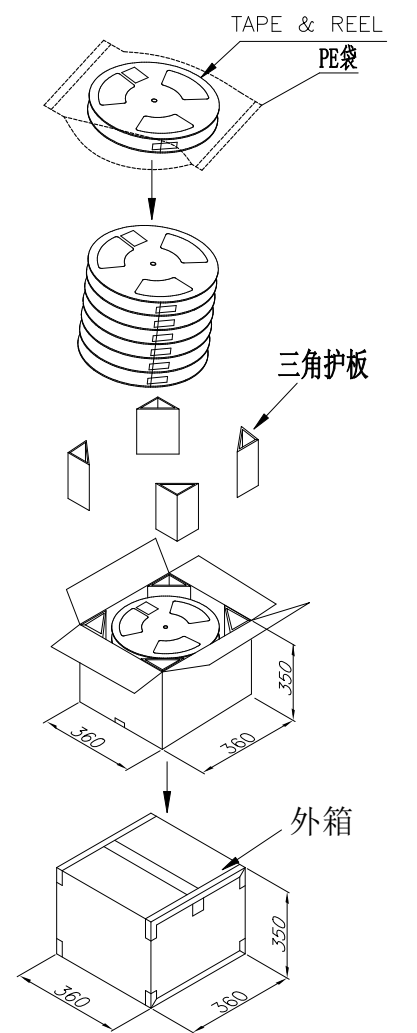

PULL OUT DIRECTION
出料方向
宽度: 24mm 载带

PULL OUT DIRECTION
出料方向
宽度: 32及以上mm 载带

借用登记
旧底图总号
底图总号
签字
日期

PART No.	61039-**-0*-****			
REEL WIDTH	24	32	44	56
PCS/REEL	1000			
REEL/BOX	12	9	7	5
BOX/PCS	12K	9K	7K	5K
CTN. SIZE	360*360*350			

GENERAL TOLERANCES			DRAWN BY	赵博群/2017.05.02
0.X	± 0.25	X. $^{\circ}$	$\pm 3^{\circ}$	CHK. BY
0.XX	± 0.12			崔华文/2017.05.02
0.XXX	± 0.05	X.X $^{\circ}$	$\pm 0.5^{\circ}$	APRV. BY
				洪新江/2017.05.02
UNIT	SIZE	SCALE	DRAWING NO.	
MM	A4	1:1	004-1039-001	

ZJ-XFE
新富尔电子
XINFUER ELECTORN CO.,LTD

新富尔电子有限公司
XINFUER ELECTORN CO.,LTD

SHEET 1 OF 1
PROD. NAME PH-nAWB
PART NO. 61039-**-0*-****

TITLE
2.0 WTB CONN. SMT SINGLE ROW RIGHT-ANGLE

芯数 Pin (n)	PART NO.	尺寸 Size		
		A	B	C
2-5	61039-020*-----61039-050*-----	24.0	11.5	---
6-8	61039-060*-----61039-080*-----	32.0	14.2	28.4
9-14	61039-090*-----61039-140*-----	44.0	20.2	40.4
15-16	61039-150*-----61039-160*-----	56.0	26.2	52.4