

REV.	DESCRIPTION	DATE
B/0	升版	2017.05.04

- Note:
- 1.Sprocket holes pitch cumulative tolerance ± 0.1 . (Accumulative Pitch ± 0.2)
 - 2.Carrier camber is within 1mm in 100mm.
 - 3.Number of connectors: 1000Pcs/REEL
 - 4.All dimensions meet EIA-481-D requirements.
 - 5.Thick ness: 0.4 ± 0.1 mm.
 - 6.Material of top fape: PET, PE, PEF
 - 7.Material of carrier fape: Poystyrene
 - 8.For tape width (dimension A) 16mm and 24mm a pilot hole is provided on one side. For tape width (dimension A) 32mm and 44mm pilot holes are provided on both sides.

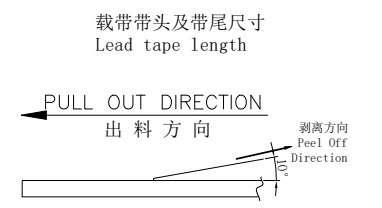
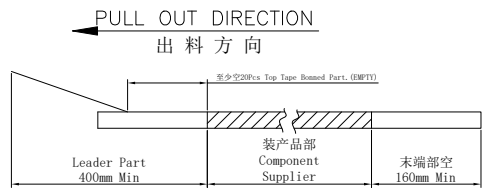
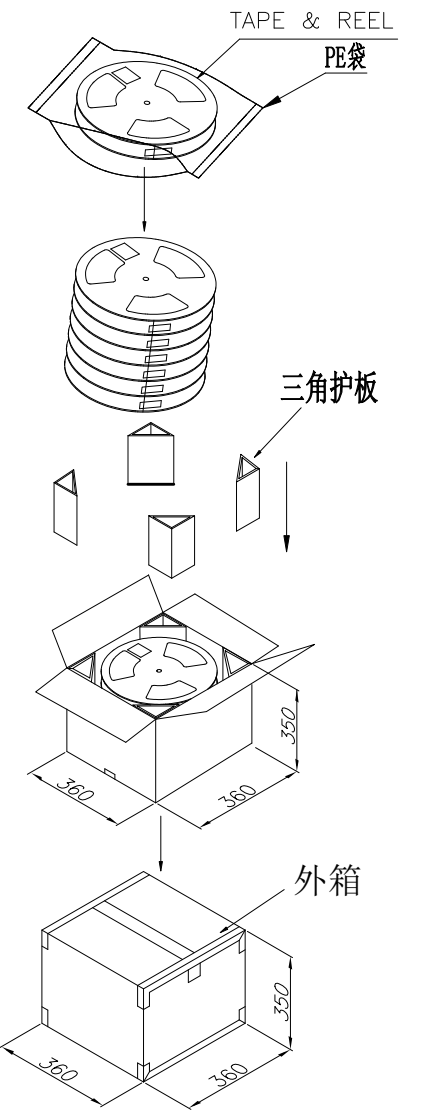

载带上下带剥离强度: 0.1N-1.3N(10g-130g)
Peeling off force of top tape: 0.1N-1.3N(10g-130g)

- ROHS管理规定:
- 1、禁止使用含有ROHS指令所限制的物质。
 - 2、对应的SGS或ITS出具的ICP-AES数据、不可测定物质的成分表,有效期一年。

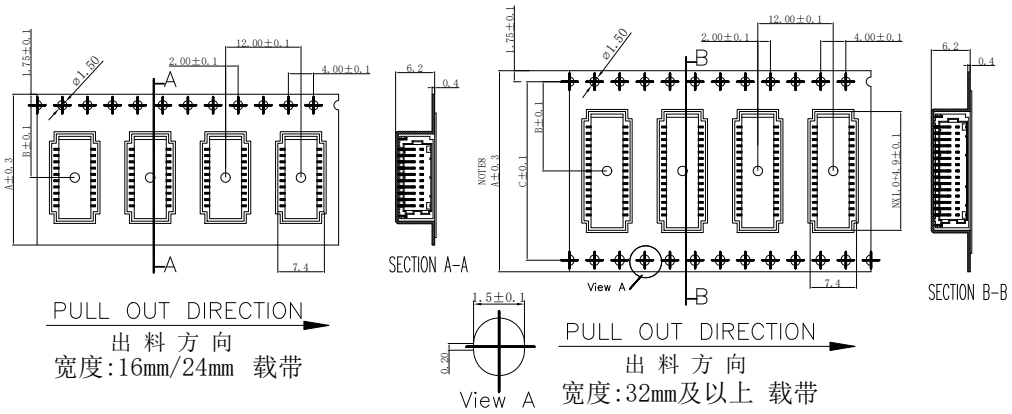
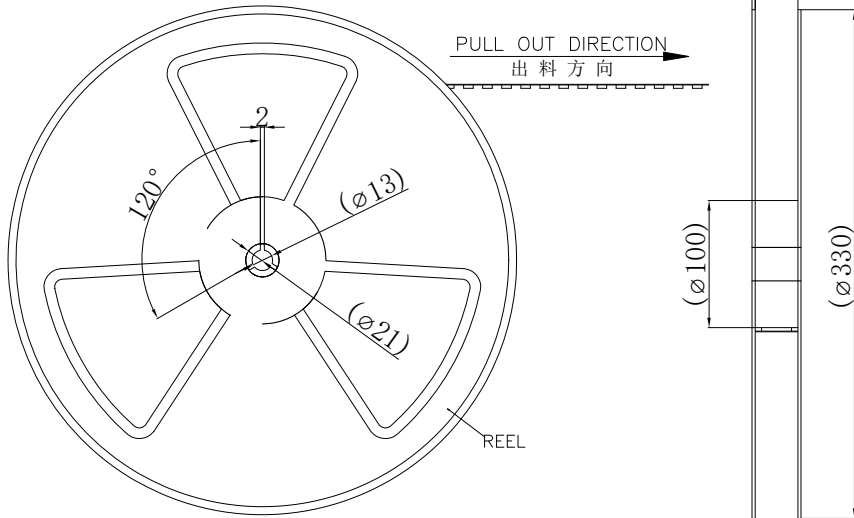

借用登记
旧底图总号

底图总号

签字

日期

PART No.	61014-**0*-****			
REEL WIDTH	24	32	44	
PCS/REEL	1000			
REEL/BOX	12	9	7	
BOX/PCS	12K	9K	7K	
CTN. SIZE	360*360*350			

GENERAL TOLERANCES			DRAWN BY	赵博博/2017.05.04
0.X	± 0.25	X.' $\pm 3^\circ$	CHK. BY	崔华文/2017.05.04
0.XX	± 0.12		APRV. BY	洪新江/2017.05.04
0.XXX	± 0.05	X.X' $\pm 0.5^\circ$	DRAWING NO.	004-1014-001
UNIT	SIZE	SCALE	1:1	

ZJ-XPE 新富尔电子有限公司
XINFUER ELECTORN CO.,LTD

SHEET 1 OF 1
PROD. NAME SHD-nAWB
PART NO. 61014-**0*-****

TITLE
1.0 WTB CONN. SMT DUAL ROW RIGHT-ANGLE

芯数 Pin (n)	PART NO.	尺寸 Size		
		A	B	C
12-20	61014-120*-****-61014-200*-****	24.0	11.5	---
30	61014-300*-****	32.0	14.2	28.4
40-50	61014-400*-****-61014-500*-****	44.0	20.2	40.4