

REV.	DESCRIPTION	DATE
A/0	升B版	2017.02.17

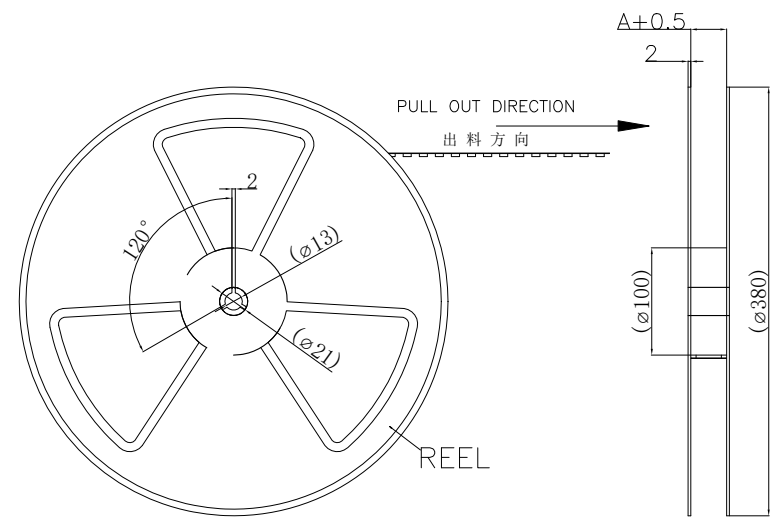

Note:

- 1.Sprocket holes pitch cumulative tolerance ± 0.1 . (Accumulative Pitch ± 0.2)
- 2.Carrier camber is within 1mm in 100mm.
- 3.Number of connectors: 1200Pcs/REEL
- 4.All dimensions meet EIA-481-D requirements.
- 5.Thick ness: 0.4 ± 0.1 mm.
- 6.Material of top fape: PET, PE, PEF
- 7.Material of carrier fape: Poystyrene
- 8.For tape width (dimension A) 16mm and 24mm a pilot hole is provided on one side. For tape width (dimension A) 32mm and 44mm pilot holes are provided on both sides.

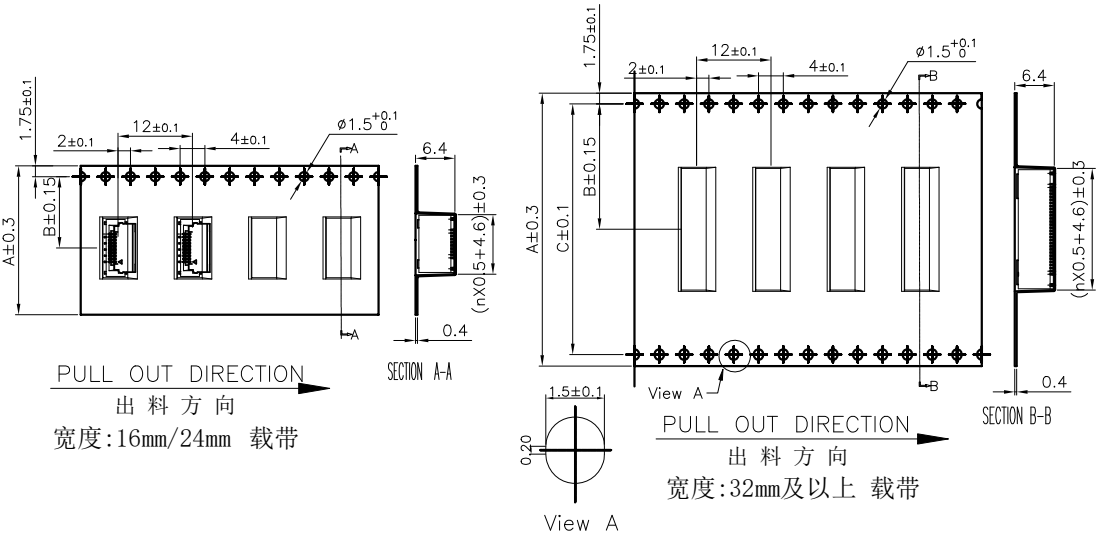
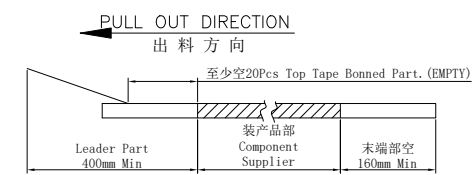
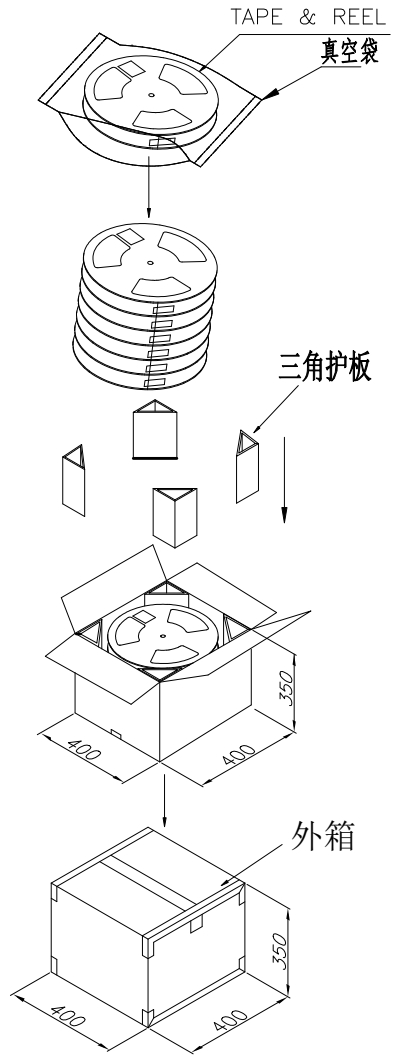

载带带头及带尾尺寸
Lead tape length

载带上下带剥离强度: 0.2N--1.0N (10g-100g)
Peeling off force of top tape:
0.2N--1.0N (10g-100g)

ROHS管理规定:

- 1、禁止使用含有ROHS指令所限制的物质。
- 2、对应的SGS或ITS出具的ICP-AES数据、不可测定物质的成分表, 有效期一年。

借用登记

旧底图总号

底图总号

签字

日期

芯数 Pin (n)	PART NO.	尺寸 Size		
		A	B	C
10--22	60103-1007-5001---60103-2207-5001	24.0	11.5	---
24--32	60103-2407-5001---60103-3207-5001	32.0	14.2	28.4
34--54	60103-3407-5001---60103-5407-5001	44.0	20.2	40.4
56--60	60103-5607-5001---60103-6007-5001	56.0	26.2	52.4
70	60103-7007-5001	72.0	34.2	68.4

PART No.	60103-**-07-5001				
REEL WIDTH	24	32	44	56	72
PCS/REEL	1200				
REEL/BOX	12	9	7	5	4
BOX/PCS	12K	9K	8.4K	6K	4.8K
CTN. SIZE	400*400*350				

GENERAL TOLERANCES			DRAWN BY	赵博博/2017.02.17
0.X	± 0.25	X. $^{\circ}$	$\pm 3^{\circ}$	CHK. BY
0.XX	± 0.12			崔华文/2017.02.17
0.XXX	± 0.05	X.X $^{\circ}$	$\pm 0.5^{\circ}$	APRV. BY
				洪新江/2017.02.17
UNIT	SIZE	SCALE	DRAWING NO.	
MM	A4	1:1	004-0103-001	

ZJ XFE 新富尔电子有限公司
XINFUER ELECTORN CO.,LTD

新富尔电子有限公司
XINFUER ELECTORN CO.,LTD

PROD. NAME 0.5-27-nPLB

PART NO. 60103-**-07-5001

SHEET 1 OF 1

TITLE 0.5 FPC CONN. ZIF SMT FRONTFLIP H=4.2 VERTICAL CONTACT