

REV.	DESCRIPTION	DATE
B/0	升B版	2017.05.06

Note:

- 1.Sprocket holes pitch cumulative tolerance ± 0.1 .(Accumulative Pitch ± 0.2)
- 2.Carrier camber is within 1mm in 100mm.
- 3.All dimensions meet EIA-481-D requirements.
- 4.Thick ness: 0.4 ± 0.1 mm.
- 5.Material of top fape:PET,PE,PEF
- 6.Material of carrier fape:Poystyrene
- 7.For tape width (dimension A) 16mm and 24mm a pilot hole is provided on one side. For tape width (dimension A)32mm and 44mm pilot holes are provided on both sides.

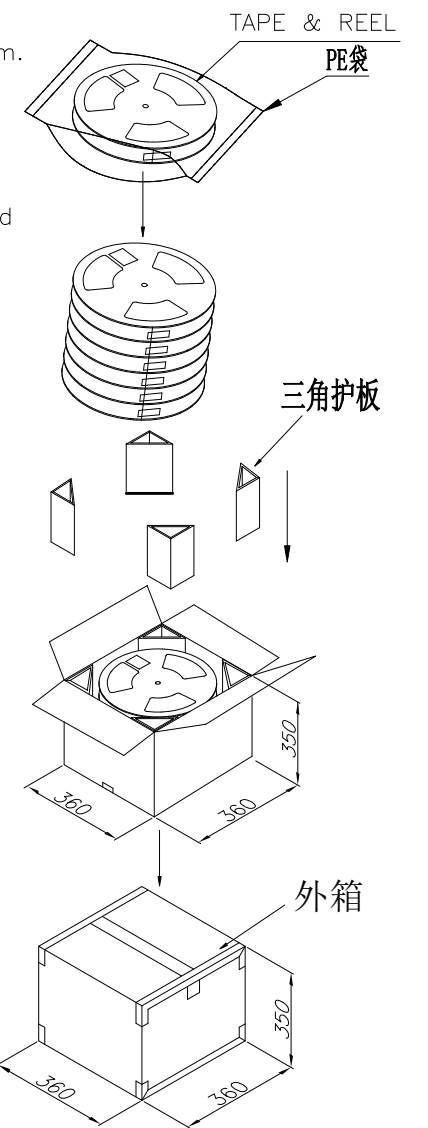
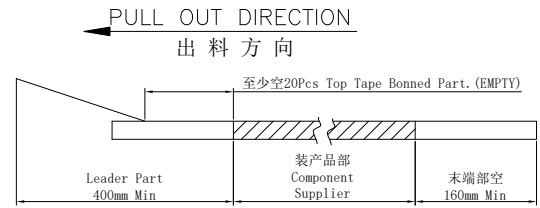
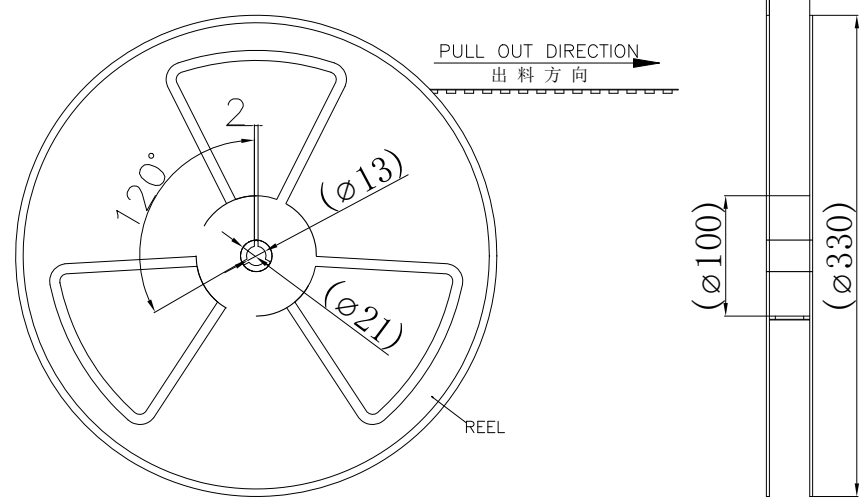

载带带头及带尾尺寸
Lead tape length

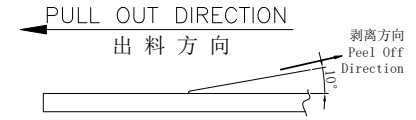

载带上下带剥离强度: 0.1N--1.3N(10g-130g)
Peeling off force of top tape:
0.1N--1.3N(10g-130g)

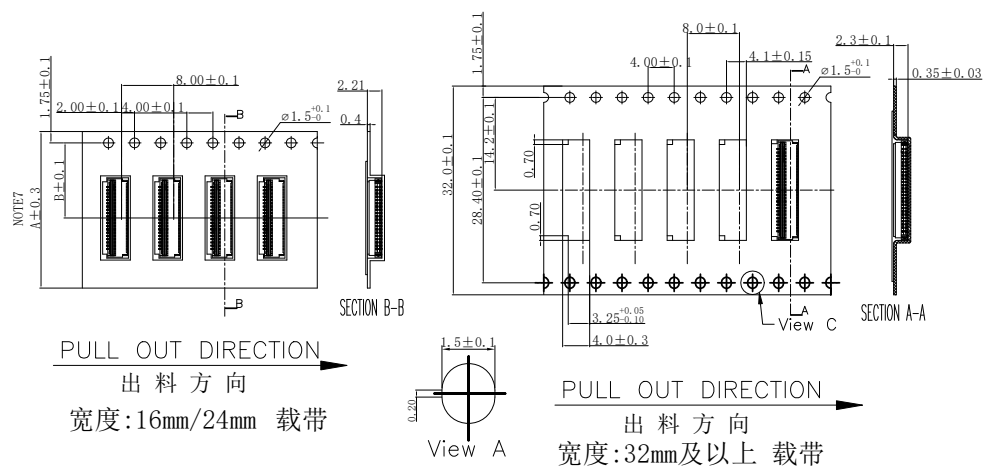

宽度:16mm/24mm 载带

宽度:32mm及以上 载带

借用登记
旧底图总号
底图总号

芯数 Pin (n)			PART NO.			尺寸 Size			PART No. 60083-**0*-500*			GENERAL TOLERANCES			DRAWN BY 赵博博/2017.05.06			新富尔电子有限公司 XINFUER ELECTORN CO.,LTD		
4-10			60083-0407-500*-----60083-1007-500*			16.0 7.5 ---			REEL WIDTH 16 24 32 / / /			0.X ± 0.25 X.* $\pm 3^{\circ}$			CHK. BY 崔华文/2017.05.06					
12-26			60083-1207-500*-----60083-2607-500*			24.0 11.5 ---			PCS/REEL 3000			0.OX ± 0.12			APRV. BY 洪新江/2017.05.06			SHEET 1 OF 1		
30			60083-3007-500*			32.0 28.4 14.2			REEL/BOX 16 12 9 / / /			0.XXX ± 0.05 X.X.* $\pm 0.5^{\circ}$			DRAWING NO. 004-0083-001			PART NO. 60083-**07-500*		
40			60083-4007-500*			44.0 40.4 20.2			BOX/PCS 48K 36K 27K / / /			UNIT MM			SCALE 1:1			TITLE 0.5 FPC CONN. ZIF SMT BACKFLIP H=1.15 VLOWER CONTACT		
日期									CTN. SIZE 360*360*350											