

REV.	DESCRIPTION	DATE
B/0	升 B 版	2016.12.19

- Note:
- 1.Sprocket holes pitch cumulative tolerance  $\pm 0.1$ . (Accumulative Pitch  $\pm 0.2$ )
  - 2.Carrier camber is within 1mm in 100mm.
  - 3.Number of connectors:  
2000Pcs/REEL
  - 4.All dimensions meet EIA-481-D requirements.
  - 5.Thick ness:  $0.4 \pm 0.05$ mm.
  - 6.Material of top fape: PET, PE, PEF
  - 7.Material of carrier fape: Poystyrene
  - 8.For tape width (dimension A) 16mm and 24mm a pilot hole is provided on one side. For tape width (dimension A) 32mm and 44mm pilot holes are provided on both sides.

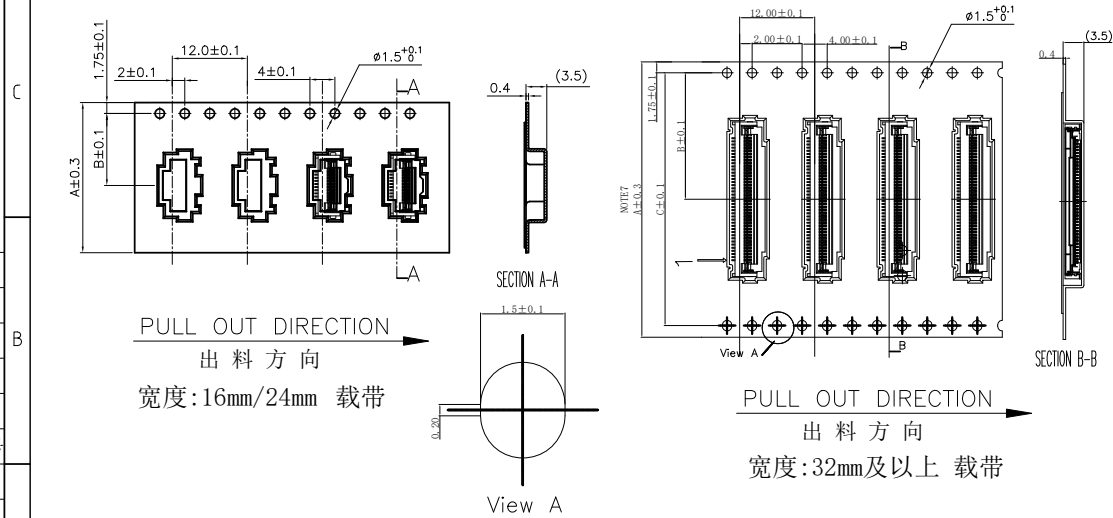
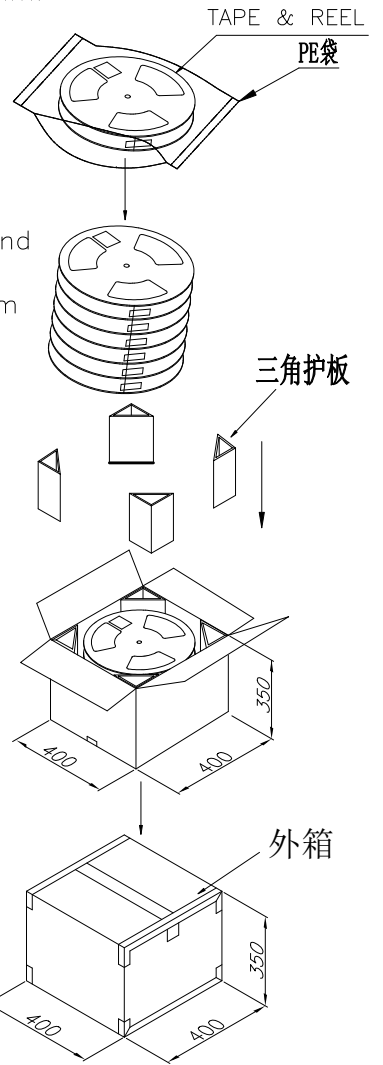
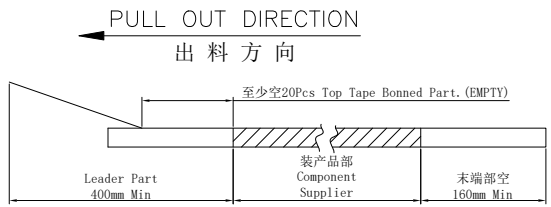
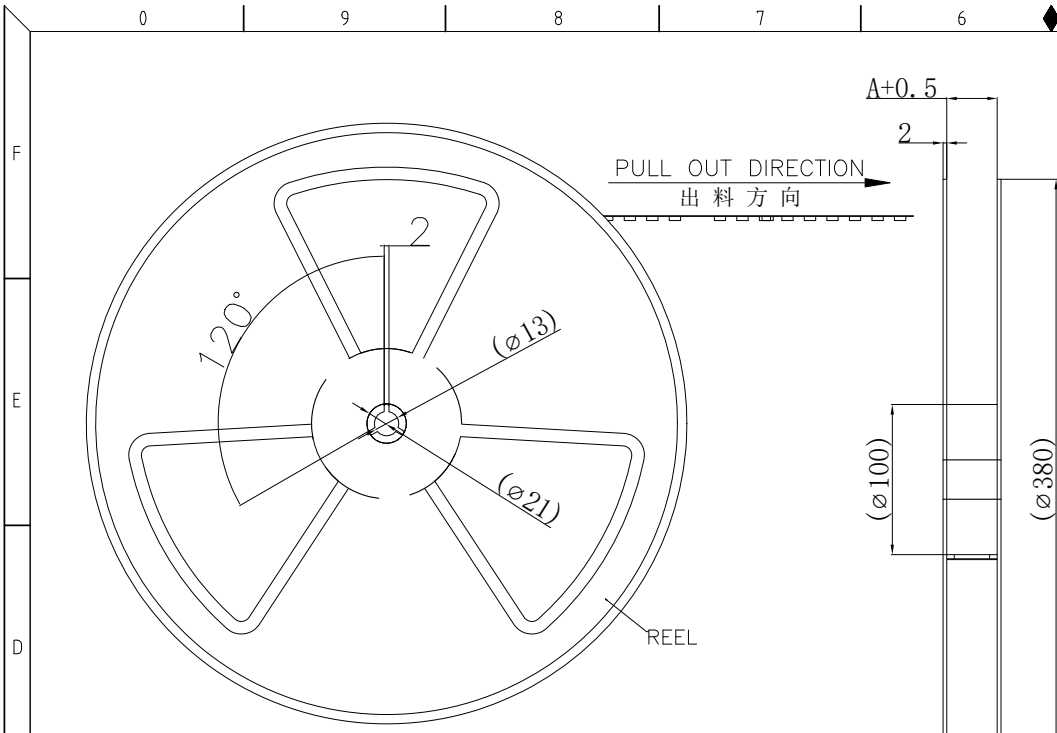

载带带头及带尾尺寸  
Lead tape length

载带上下带剥离强度: 0.1N--1.3N(10g-130g)  
Peeling off force of top tape:  
0.1N--1.3N(10g-130g)

ROHS管理规定:  
1、禁止使用含有ROHS指令所限制的物质。  
2、对应的SGS或ITS出具的ICP-AES数据、不可测定物质的成分表,有效期一年。

借用登记  
旧底图总号  
底图总号

芯数 Pin (n)	PART NO.	尺寸 Size		
		A	B	C
4-6	60078-0407-100*---60078-0607-100*	16.0	7.5	---
7-23	60078-0707-100*---60078-2307-100*	24.0	11.5	---
24-31	60078-2407-100*---60078-3107-100*	32.0	14.2	28.4
32-59	60078-3207-100*---60078-5907-100*	44.0	20.2	40.4
60-80	60078-6007-100*---60078-8007-100*	56.0	26.2	52.4

PART No.	60078-**07-100*				
REEL WIDTH	16	24	32	44	56
PCS/REEL	2000				
REEL/BOX	16	12	9	7	5
BOX/PCS	32K	24K	18K	14K	10K
CTN. SIZE	400*400*350				

GENERAL TOLERANCES			DRAWN BY	赵博群/2016.12.19
0.X	$\pm 0.25$	X.* $\pm 3^*$	CHK. BY	崔华文/2016.12.19
0.XX	$\pm 0.12$		APRV. BY	洪新江/2016.12.19
0.XXX	$\pm 0.05$	X.X.* $\pm 0.5^*$	DRAWING NO.	004-0078-001
UNIT	MM	SCALE	1:1	

		<b>新富尔电子有限公司</b> XINFUER ELECTORN CO.,LTD	
SHEET	1 OF 1	PROD. NAME	0.5-22-nPBX
PART NO.		60078-**07-100*	
TITLE 0.5 FPC CONN. ZIF SMT FRONTFLIP H=2.5 DOUBLE LOWER CONTACT			