

REV.	DESCRIPTION	DATE
B/0	升B版	2016.12.16

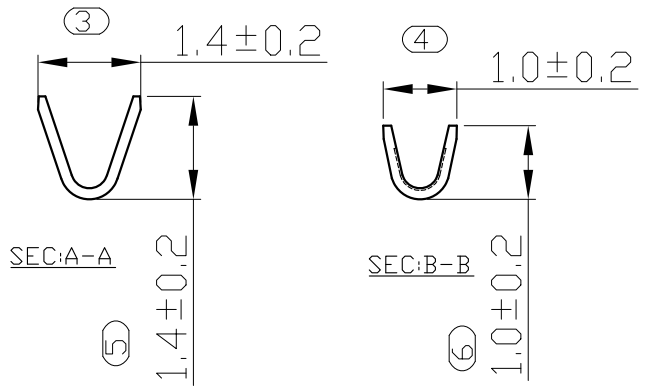
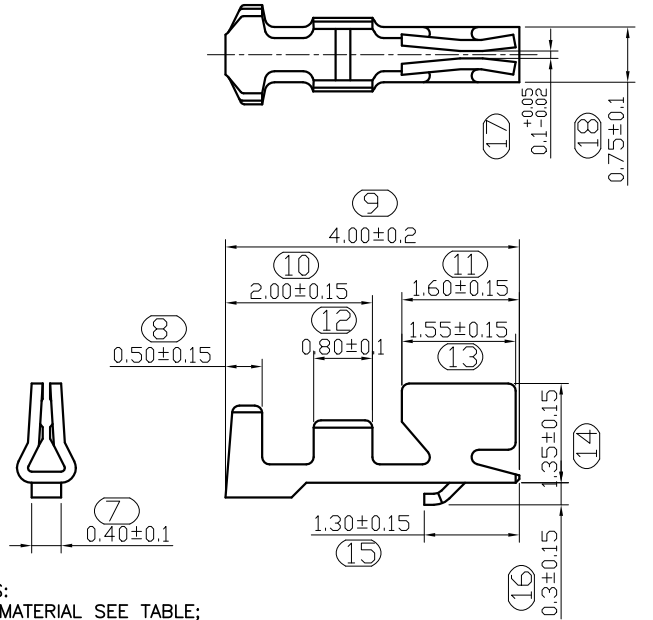
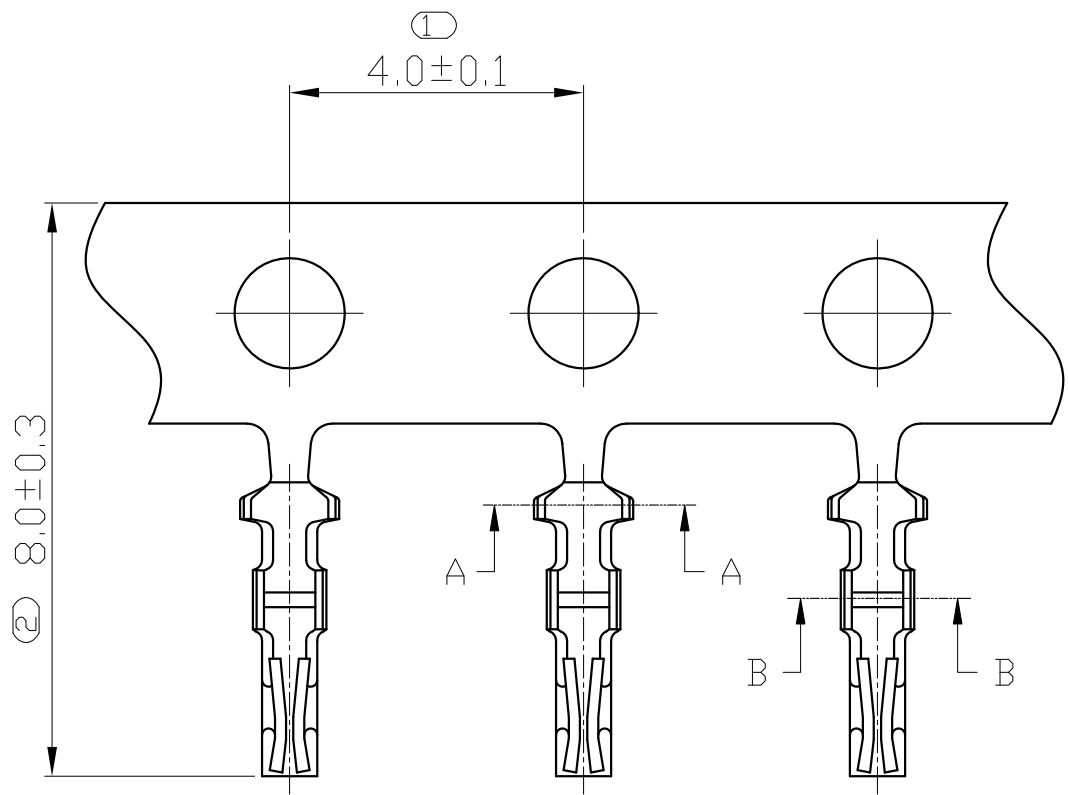

NOTES:
 1. MATERIAL SEE TABLE;
 2. PLATING SEE TABLE;
 3. RATING
 3-1. OPERATING TEMPERATURE: -25~85°C
 3-2. OPERATING VOLTAGE: 150V AC/DC
 3-3. CURRENT RATING: 1.0 AMPS(28#)
 3-4. DIELECTRIC WITHSTANDING VOLTAGE:
 800V AC/Minute;
 3-5. INSULATION RESISTANCE:1000MΩ
 Min;
 3-6. CONTACT RESISTANCE:0.03Ω Max;
 4. PART NO.
 21005-2T01-1001
 SERIES Serial Number
 Hardware
 Plating:
 1=BRIGHT-TIN 80μ"Min
 OVER Ni 30μ"Min..

借用登记
 旧底图总号
 底图总号
 签字
 日期

1	152-1005-001	端子 Terminal	磷青铜 C5191	1	电镀(铜): 整个表面镀底镍30u"MIN,再镀亮锡80u"MIN.
序号	图号	名称	材料	数量	附注
GENERAL TOLERANCES			DRAWN BY 赵博博/2016.12.16	新富尔电子有限公司 XINFUER ELECTORN CO.,LTD	
0.X	±0.25	X.° ±3°	CHK. BY 崔华文/2016.12.16		
0.XX	±0.12		APRV. BY 洪新江/2016.12.16		
0.XXX	±0.05	X.X° ±0.5°	DRAWING NO. 052-1005-001	SHEET 1 OF 1	PROD. NAME 1.0T-T/SHD-T
UNIT MM	SIZE A4	SCALE 1:1	PART NO. 21005-2T01-1001		
			TITLE 1.0 WTb CONN. PLUG CRIMP TERMINAL		